

Single Channel Vehicle detector User Guide

Connections

Pin	ML-100	ML-102
1	100-240V AC	12-24VADC
2	100-240V AC	12-24VADC
3	Pulse B Relay N.O	
4	Pulse B Relay COM	
5	Presence A Relay N.O	
6	Presence A Relay COM	
7	Loop	
8	Loop	
9	Chassis Ground	
10	Presence A Relay N.C	
11	Pulse B Relay N.C	

ML-100

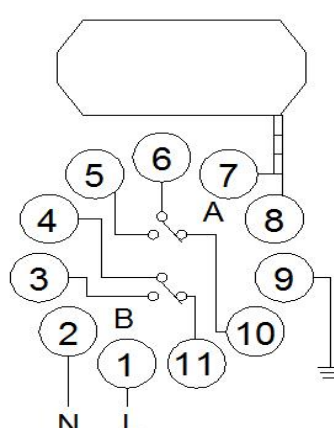

ML-102

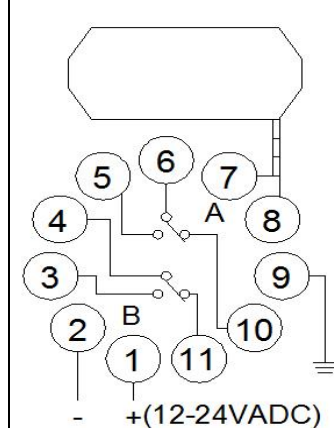

Indicates and Switch

(1) **Power Led:** RED power LED indicates “Power ON”

Detecting Led: Continuously On: Indicates vehicle detection.

Blinking slowly: Indicates loop is short circuit or the number of twists after the loop is not enough.

Blinking fast: Indicates loop is open circuit or too many twists after the loop.

(2) **Switch 1 (Trimpot), Sensitivity Selection**

Sensitivity of the loop can be adjusted by the trimpot labeled “Sensitivity”. User can select 16 different setting by turning the trimpot with 0 being the least sensitive and “F” being the most sensitive.

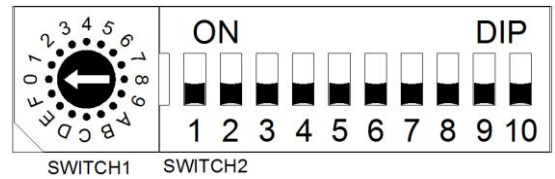

(3) **Switch 2 (Dipswitch Settings)**

1. **DIP 1 & DIP 2 Setting Special Functions**

DIP NO.	DIP MODE	Function
DIP 1	ON	Output has 2 seconds delay. (No relay output if the vehicle speed is over 8km/h).
DIP 2	ON	Increase sensitivity to avoid unwilling relay off for leaving vehicle especially for trailer.

2. **DIP 3 & DIP 4 Setting Relay B Output**









DIP NO.	DIP 3	DIP 4	Relay B Output
DIP MODE	OFF	OFF	When vehicle is moving out, output for relay B is 200m/s.
	ON	OFF	When the vehicle has left, output for relay B is 600m/s.
	OFF	ON	Relay B will be present output. No reaction on Dip switches 3.
	ON	ON	Can be used to test the Loop. If the loop is faulty, Relay B will be on and it will switch off once the fault is fixed.



3. DIP 5 Setting Automatic Reset

DIP NO.	DIP 5	Present Mode
DIP MODE	ON	Vehicle can be permanently present (no auto-reset , unless vehicle has left or manual reset)
	OFF	Normal mode (automatic reset after 30 minutes present of vehicle, used to solve the mistake operation. If it is recommended).

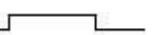
4. DIP 6 & DIP 7 & DIP 8 Setting Relay A Delay

DIP NO.	DIP 6	DIP 7	DIP 8	Delay	A Output 
DIP MODE	OFF	OFF	OFF	0 sec	Output 
	ON	OFF	OFF	2 sec	Output 
	OFF	ON	OFF	5 sec	Output 
	ON	ON	OFF	8 sec	Output 
	OFF	OFF	ON	10 sec	Output 
	ON	OFF	ON	15 sec	Output 
	OFF	ON	ON	20 sec	Output 
	ON	ON	ON	30 sec	Output 

5. DIP 9 & DIP 10 Setting Frequency (40 K to 100 KHz). Used to avoid the interference

DIP NO.	DIP 9	DIP 10	Frequency
DIP MODE	OFF	OFF	High
	ON	OFF	Medium-High

DIP NO.	DIP 9	DIP 10	Frequency
DIP MODE	OFF	ON	Medium-Low
	ON	ON	Low

* In the application, where two or more loop detectors and sensing loops have been installed, set one detector to high frequency and the other set to low frequency to minimize the effects of cross-talk between the two systems(The sensing loops and detectors should be positioned at least 2m apart)

Reset Button: Please note: The LD-100 must be reset every time a setting change is made to the Dip switches.

Detector position and installation

- _ Install the detector in a weatherproof housing.
- _ The detector should be as close to the sensing loop as possible.
- _ The detector should always be installed away from strong magnetic fields.
- _ Avoid running high voltage wires near the loop detectors.
- _ Do not install the detector on vibrating objects.
- _ When the control box is installed within 10 metres of the loop, normal wires can be used to connect the control box to the loop. More than 10 metres requires the use of a 2 core shielded cable. Do not exceed 30 metres distance between control box and loop.
- _ When installation, please keep the product plug and socket in the vertical direction

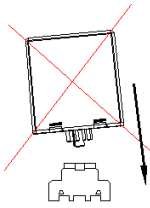

Wrong installation

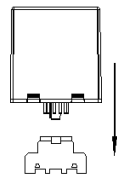

The correct installation

Loop Installation:

The loops are sealed using a “quick-set” black epoxy compound or hot bitumen mastic to blend with the roadway surface.

Loop perimeter	Cylinder numbers
3 ~ 4 M	6
4 ~ 6 M	5
6 ~ 10 M	4
10 ~ 20 M	3
20 M~ UP	2

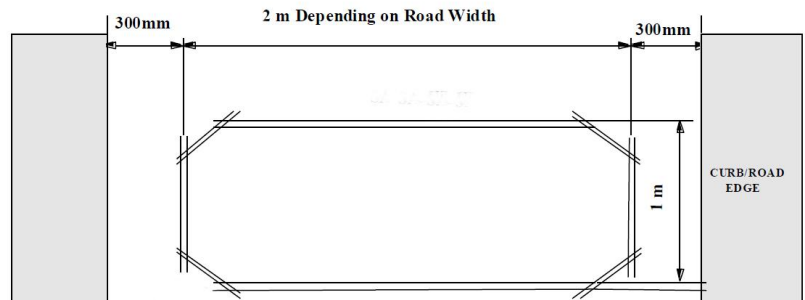

Troubleshooting

Symptoms		Solution
If the detector is not working		Press reset
If red led indicator is not fully lit		Check for power supply
If green led indicator:	Blinks slowly	It maybe because the loop is short circuit or the no: of turns is not enough.
	Blinks faster	It maybe because the loop is open or the no: of turns is too many.
If no: of turns is not enough		Lower the frequency (if the frequency is still too high, you must add more turns).
If no: of turns is too many		Higher the frequency (if the frequency is still too low, you must remove some turns).

