

Digital selector with 2 buttons and 2 channels, used with the receiver BeSafe RX New and the interface INT 2206 NEW to electronic panels for the automation of windows.

**IMPORTANT FOR THE INSTALLER**

- The control unit must be supplied by SELV (safety extra low voltage) or SELV equivalent power limited source.
- All operations, which require the opening of the case (installation, programming and repair, etc.), must be carried out by experienced staff.
- The fixing of power cables and connection cables must be guaranteed by assembling cable glands supplied optional.
- Secure the plastic cover of the device to a wall inserting the mounting screws in the provided spaces.

**IMPORTANT FOR THE USER**

- The device can be used by children over the age of 8 years or people with limited psychological or physical abilities or with little knowledge and experience only when supervised or trained on the operation and how to use safely to understand the dangers involved in its use.
- These instructions are available on the website [www.seav.com](http://www.seav.com)
- Do not allow children to play with the device and keep the radio controls out of their reach.
- Frequently examine the plant to detect any signs of damage. Do not use the device if you need a repair.
- Always remember to turn off the power before cleaning or maintenance works.
- The cleaning and maintenance works shall not be made by children without being supervised.

**ATTENTION:** keep this instruction manual and respect the important safety instructions contained inside. The non-compliance with the prescriptions may cause damages and serious accidents.

The product:

**BeSafe Keyboard**

Complies with the requirements of the Directive EMC 2014/30/EU.



**TECHNICAL CHARACTERISTICS**

- Supply: 12 Vdc
- Max consumption: 20 mA
- Working temperature: -10°C ÷ 55°C
- Dimensions: 90 x 65 x 30 mm.
- Protection degree: IP 44

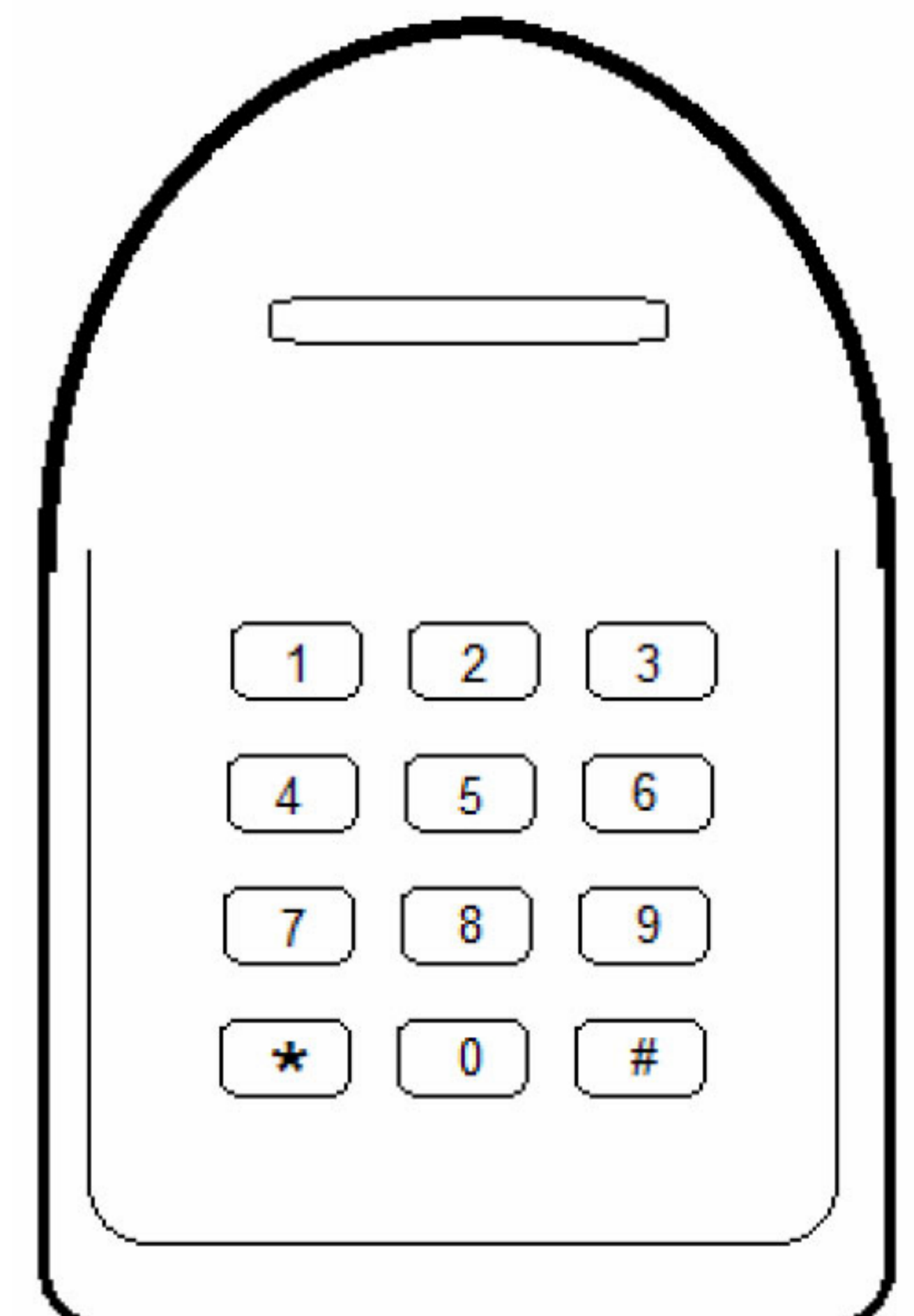
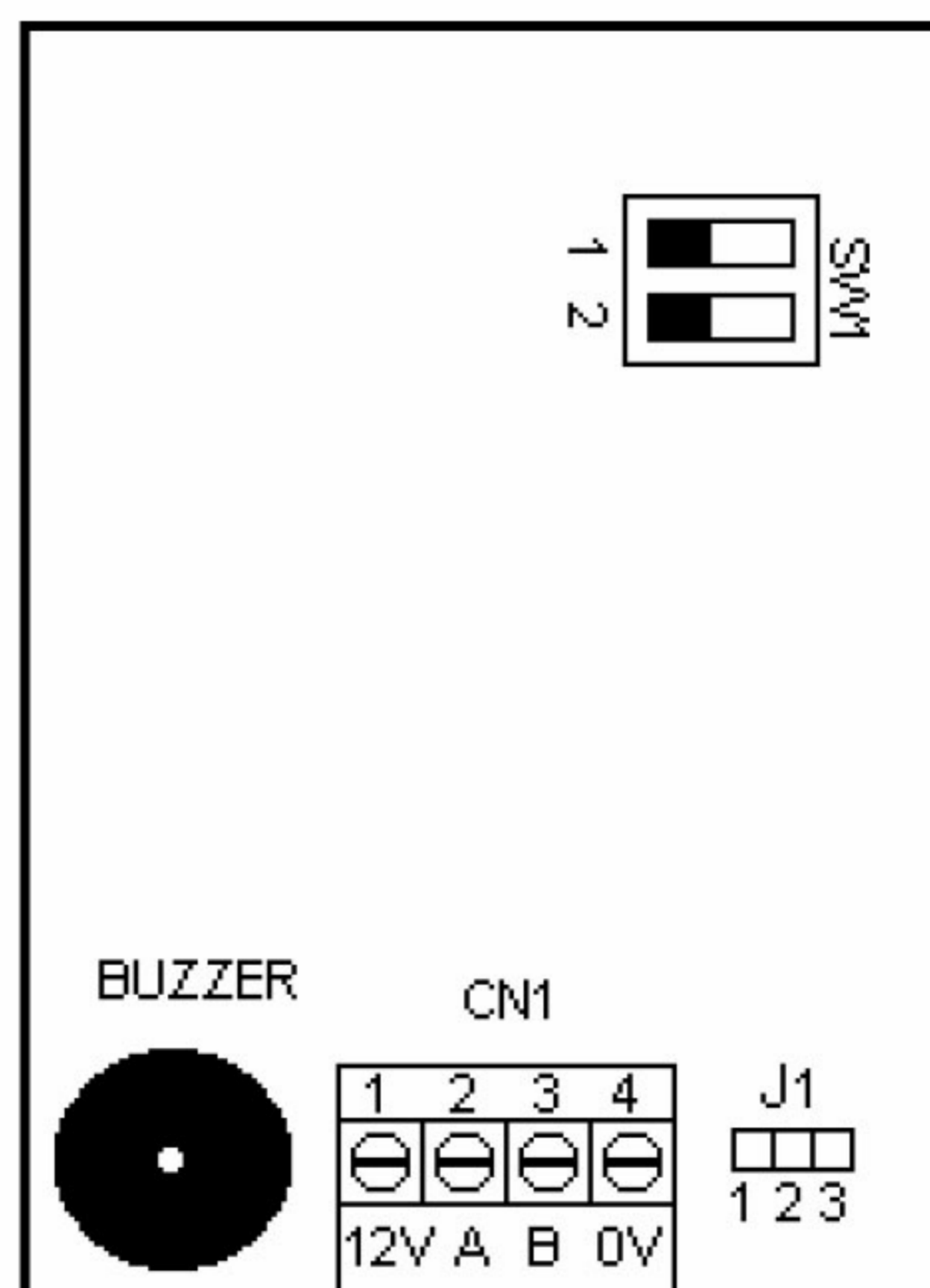



**CONNECTING BUS TO THE RECEIVER BESAFE RX NEW OR TO THE INTERFACE INT 2206 NEW**

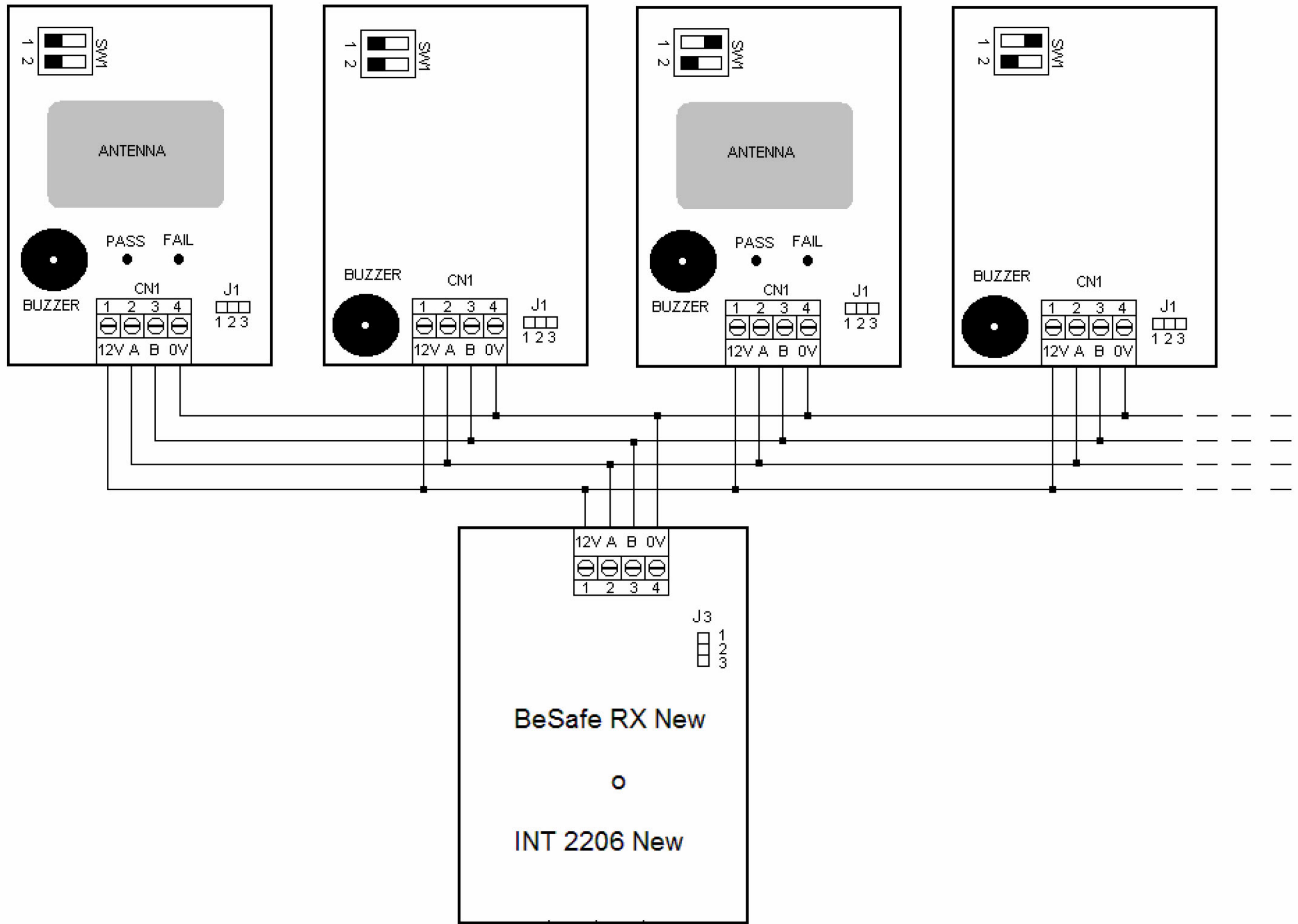

It is possible to connect to every single BeSafe RX New receiver or Interface INT 2206 NEW up to 2 BeSafe Keyboard devices. By dip switch SW1 in advance you must assign to each BeSafe Keyboard its own address:

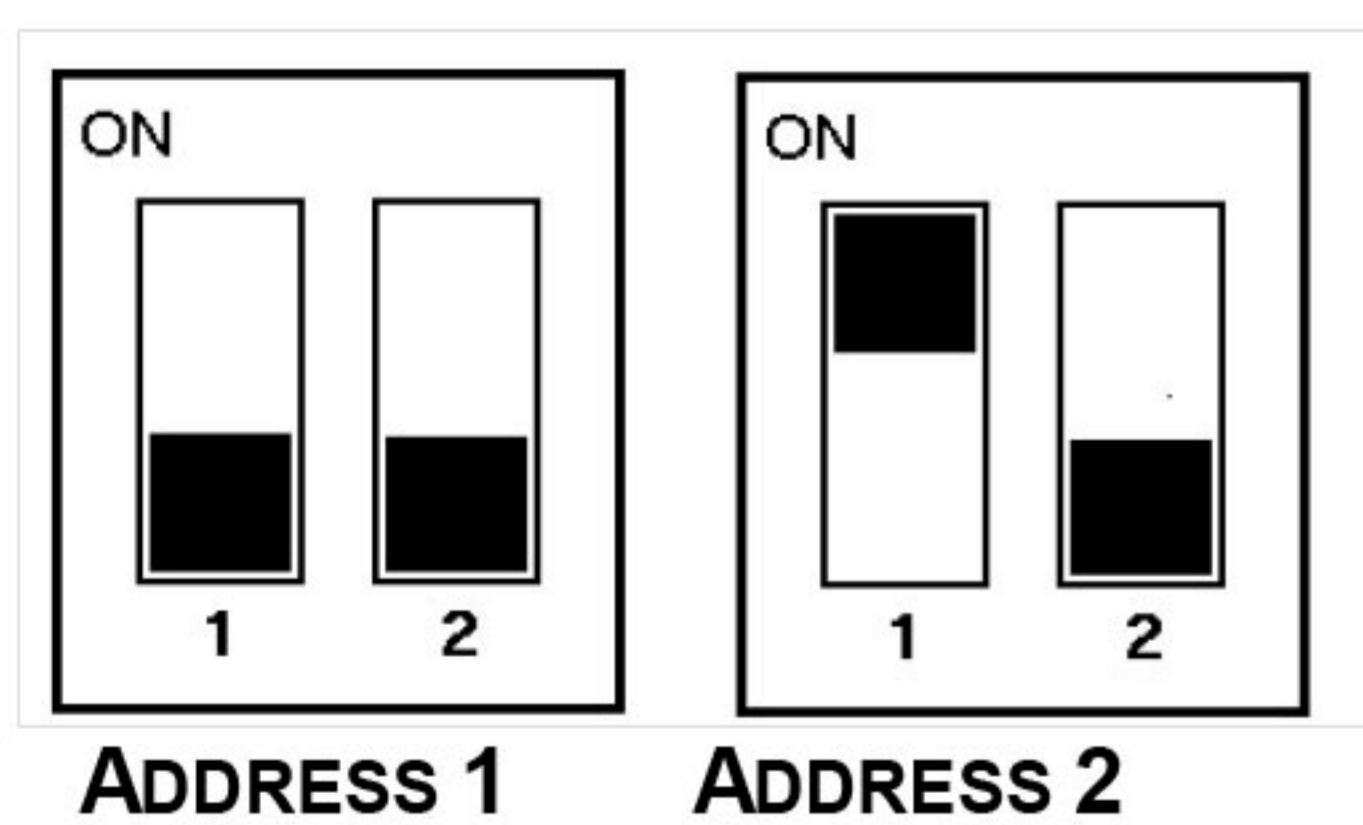

The communication is via standard RS485. It is possible to make connections with cable lengths up to 100 m. In case of communication problems it is recommended to move the jumper J1 to 1-2 (insertion of the terminating resistor) on devices located at the ends of the links:  
 J1 pos. 1-2 = inserted termination resistance.  
 J1 pos. 2-3 = not inserted terminating resistor (default).

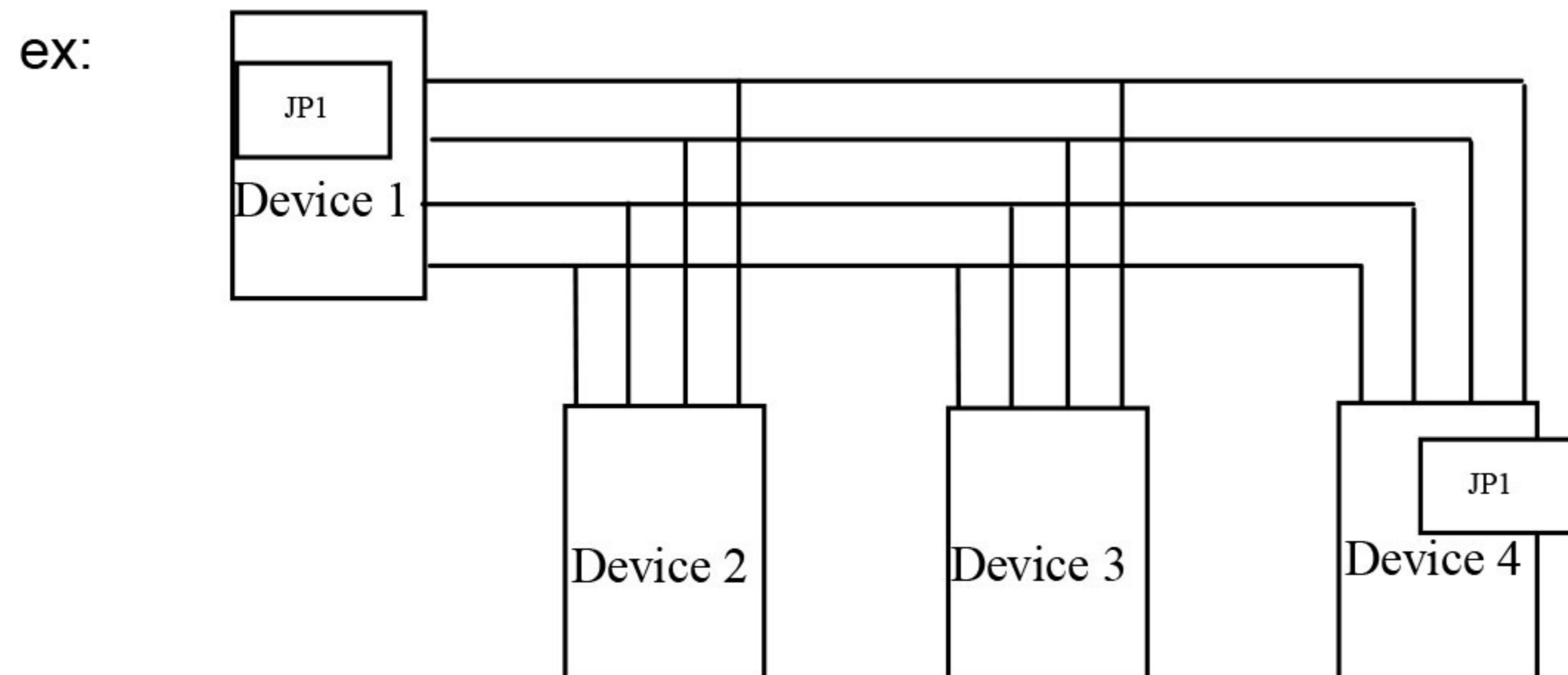

In the example above the jumpers should be placed on devices n. 1 and n. 4, irrespective of the type of device.



## OPERATION OF THE PRODUCT

The device Besafe Keyboard allows to send two different codes, each per channel, after having entered the right combination. This code is sent via RS485 to the Receiver BeSafe RX New or Interface INT 2206 New, that converts every code to a command for the activation of one or more windows.

After having entered the combination, the button **\*** is used for sending the code of the 1° channel, while the button **#** is used for sending the code of the 2° channel. If the entered combination is not right by pushing the button related to the channel, the code will not be transmitted and the acoustic signal warns that the combination is wrong.

During the normal use in fact, an acoustic signal warns the user of the status of operations, as the following chart:

Acoustic signal	Status
1 short beep	Pressure of a button
3 short beep	Input of programming
1 long beep	- Wrong entered code - Programming: input current combination, to insert new combination.
2 short beep	- Correct entered code.
2 long beep	Programming: input new combination, insert it again.
4 short beep	Output of programming with achievement.
5 rapid beep	Output of programming for timeout or for wrong combination insert
6 rapid beep	Wrong combination

The device is equipped with light of the keyboard, that turns on with the pressure of the first button and automatically turns off after 10 sec. Of unusing.

During standby, the light emits short flashes to make easier finding the device in the dark.

Example of operation: if the programmed combination for channel 1 is "12345". In order to send the code of channel 1, the user has to:

- press on the keyboard the sequence "12345"
- push the button **\***.

## CHANGE OF THE ENTER COMBINATION AT USE

The combination is a sequence of digits from 0 to 9. Each combination allows you to enter up to 8 digits. While composing the combination change from the push of a button to the next button it can follow up to 10 sec., after that the device will exit the programming for time out reporting the event with 5 beeps and in order to enter the combination it must start from the beginning.

In the factory configuration the device has a standard combination:

- Standard combination to send the code: **1111** valid for both channels 1 and 2.

### **Change of the combination (button **\***)**

Push and keep pushing in the same time the buttons **\*** and **#** for a moment. The device will alert by 3 short beeps the beginning of the programming. Press the current combination ( in case of first programming the combination is 1111) and push the button **\***. If the related combination is wrong, the device will alert this with 5 rapid beeps and the programming will finish.; if instead the combination is right, the device will emit a long beep and the user has to enter the new combination and push the button **\***. The device will emit 2 long beeps to alert the user to enter again the new combination, finishing with the button **\***. If the operation is successful the device will alert the end of the operation by 4 short beeps. After 10 sec. Without any operation, the device exit the programming, alerting of the incomplete operation by 5 rapid beeps.



The ID Serial Code “ ID CODE “ of transmission is a sequence of digits from 0 to 9.

Each combination allows you to enter up to 8 digits.

While composing the combination change from the push of a button to the next button it can follow up to 10 sec., after that the device will exit the programming for time out reporting the event with 5 beeps and in order to enter the combination it must start from the beginning.

In the factory configuration the device has a standard ID Serial Transmission for both channels 1 and 2:

- Standard sequence of ID serial code “ ID CODE “ of transmission: **12345678**

### ***Change of the ID Serial Transmission “ ID CODE “ (button # )***

Push and keep pushing in the same time the buttons \* and # for a moment . The device will alert by 3 short beeps the beginning of the programming. Press the current combination already stored or standard combination and push the button \*. If the entered combination is wrong, the device will alert this with 5 rapid beeps and the programming will finish.; if instead the entered combination is right, the device will emit a long beep and the user will press the new ID Serial Code “ ID CODE “ of transmission and push the button #. The device will emit 2 long beeps to alert the user to enter again the new combination, finishing with the button #. If the operation is successful the device will alert the end of the operation by 4 short beeps. After 10 sec. Without any operation, the device exit the programming, alerting of the incomplete operation by 5 rapid beeps.