

# BeLED Flashing/Acoustic Beacon

GB

Flashing Beacon with integrated acoustic warning device, available in various power supply voltage models, for visual and acoustic signalling for movement automations such as gates, garage doors and more.

- Mod. **BeLED 230VAC** : 230V~ 50/60Hz 4W max.
- Mod. **BeLED 12-24V AC-DC** : 12-24V AC-DC 4W max.

## TECHNICAL DATA

- Power supply: see model
- 4 x 1W LED : 4W Max.
- Working temperature: -10÷55°C
- Dimensions: 140 x 100 x 70 mm.
- Container: PMMA - ABS UL94V-0 ( IP54 )

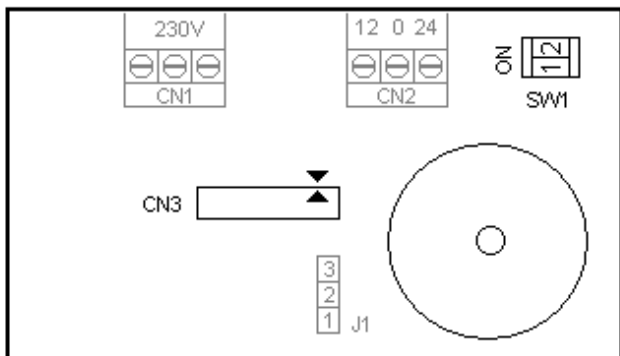

## INSTALLATION OF THE FLASHING BEACON

For excellent functioning, it is very important to choose the place of installation carefully. Verify that the chosen surface is capable of guaranteeing stable fixing. Verify that the chosen position can be accessed easily for future maintenance operations.

## INITIAL FUNCTIONING CONDITION

The device must be exclusively connected to a source of power that is suitable based on the model that was purchased; a flashing electronic circuit is already integrated inside of it.

## OPERATING FEATURES:

The flashing beacon is made of a transparent dome that protects internal circuits and correctly diffuse light emitted by the LEDs, and a base used for fixing it and passing cables. When the device is active it warns the user that automation is in movement using the luminous and acoustic signals, depending on the settings.

## SOUND SETTINGS:

Using the J1 Jumper it is possible to activate or deactivate the acoustic signal as follows:

**J1 not inserted:** the flashing is accompanied by an acoustic signal whose tone and level is high.

**J1 position 1 - 2:** the acoustic signal is disabled.

**J1 position 2 - 3:** the flashing is accompanied by an acoustic signal whose tone and level is lower.

## MANOEUVRE COUNTER SETTINGS:

Based on the position of the SW1 dip switches, the device counts a determined number of manoeuvres (switch on) until it signals the need for maintenance. Once the set number of manoeuvres has been reached, flashing is replaced by a fixed light.

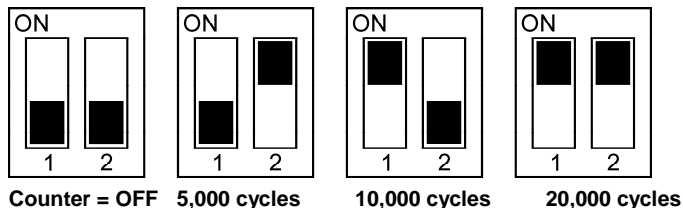

**Counter = OFF:** the device is supplied from the factory with the manoeuvre counter disabled. The flashing beacon will continue to work without any limit in manoeuvres, with flashing and acoustic signals, depending on the settings. Activate the flashing beacon at least once in this mode to reset the manoeuvre counter.

**No. 5,000 cycles:** The device functions normally with flashing and acoustic signalling, if set, until it reaches 5,000 cycles (switch on), subsequently it continues the visual and acoustic signalling, depending on the settings, but the light it emits is fixed and no longer intermittent. This state remains until the switches are brought to OFF and the device is activated at least once. In order to start a new count, set the SW1 Switch once again at the desired number of manoeuvres.

**No. 10,000 cycles:** The device functions normally with flashing and acoustic signalling, if set, until it reaches 10,000 cycles (switch on), subsequently it continues the visual and acoustic signalling, depending on the settings, but the light it emits is fixed and no longer intermittent. This state remains until the switches are brought to OFF and the device is activated at least once. In order to start a new count, set the SW1 Switch once again at the desired number of manoeuvres.

**No. 20,000 cycles:** The device functions normally with flashing and acoustic signalling, if set, until it reaches 20,000 cycles (switch on), subsequently it continues the visual and acoustic signalling, depending on the settings, but the light it emits is fixed and no longer intermittent. This state remains until the switches are brought to OFF and the device is activated at least once. In order to start a new count, set the SW1 Switch once again at the desired number of manoeuvres.

#### IMPORTANT FOR THE INSTALLER

- The product does not have any type of isolating device for the 230 Vac line. It will therefore be the responsibility of the installer to arrange an isolating device inside the plant. It must be positioned where it can be protected from accidental closing, according to that prescribed in point 5.2.9 of EN 12453.
- Wiring of the various electrical components outside of the product must be carried out in compliance with that prescribed in Standard EN 60204-1 and its amendments at point 5.2.7 of EN 12453. Power supply and connection cables must be fixed using the cable glands that can be supplied as an optional.
- Pay attention while making holes in the outside casing, when passing cables for connection and power supply and assembling the cable glands, that everything is installed in a way that keeps IP protection characteristics of the panel unchanged as much as possible.
- Pay careful attention when fastening the cables so that they are anchored in a manner that is stable.
- The back casing is not equipped with suitable predispositions for fixing to a wall (predisposition for holes for fixing using anchors or holes for fixing using screws). Plan and implement necessary solutions to achieve an installation that does not alter the IP protection.

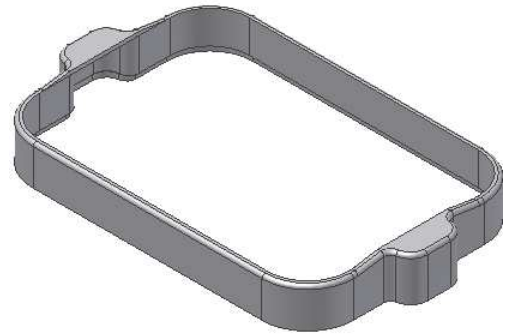

#### IMPORTANT FOR THE INSTALLER

- ATTENTION: keep this instruction manual and respect the important safety prescriptions contained herein. The non compliance with the prescriptions may cause damages and serious accidents.
- The device must never be used by children or persons with reduced physical-psychological abilities, unless supervised or trained on the functioning and the use modalities.
- Frequently examine the system to detect any signs of damaging. Do not use the device if a repair intervention is necessary.

#### Attention

All operations which require the opening of the casing (cables connection, programming, etc.) must be carried out by expert personnel during installation. For any further operation which requires the casing to be re-opened (re-programming, repair or installation changes) contact the after-sales assistance.

the product:

#### **BeLED 230VAC - BeLED 12-24V AC-DC**

is in compliance with the specifications of Directives  
EMC 2004/108/EC, LVD 2006/95/EC.

